

**VALTORC**

WWW.VALTORC.COM  
AJBENTAL@VALTORC.COM  
1 (866) VALTORC

# PNEUMATIC RACK & PINION ACTUATORS



## DOUBLE ACTING SPRING RETURN

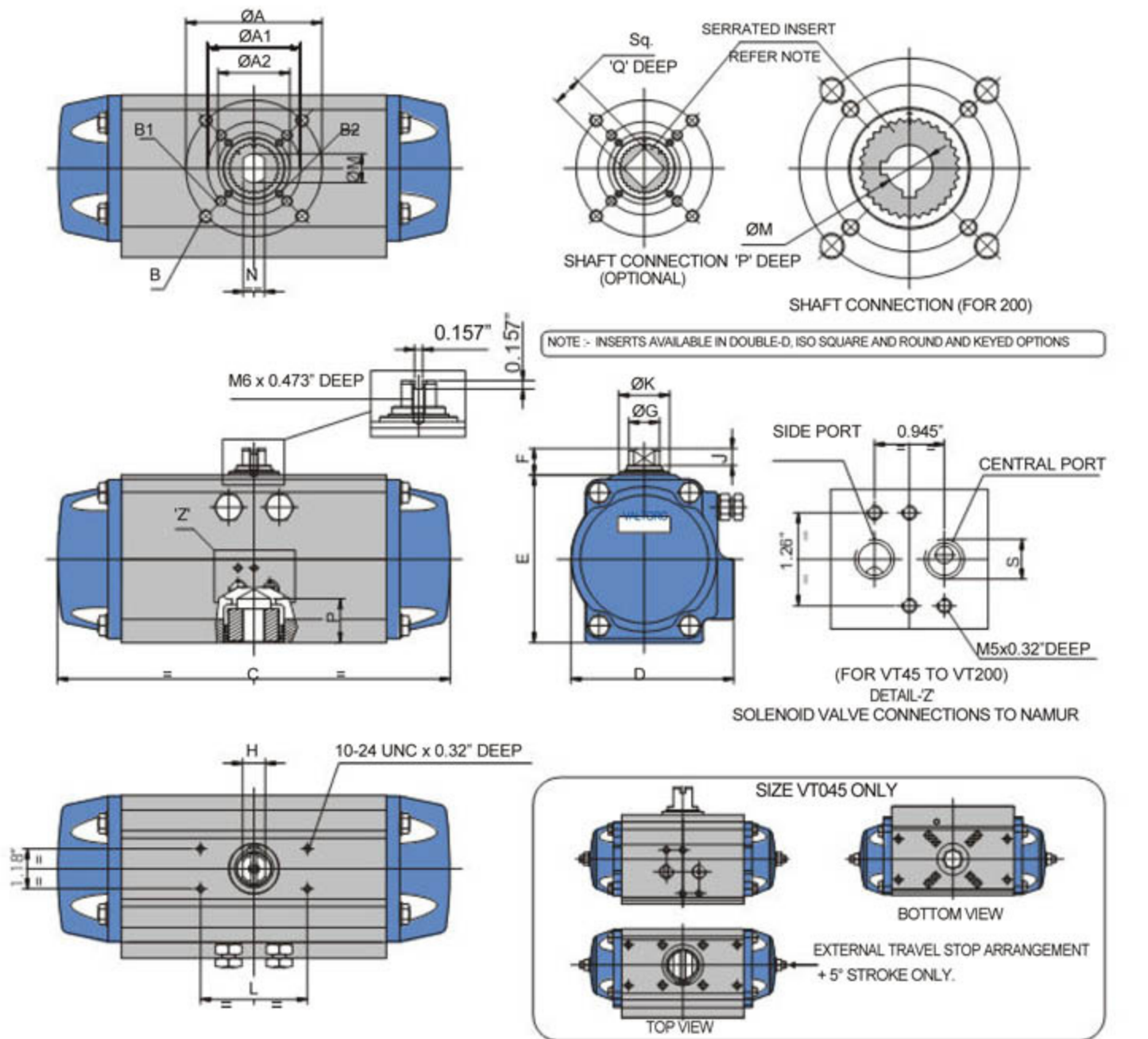

## Dimensions (Inch)

SIZE	ØA	ØA1	ØA2	ØB	ØB1	ØB2	C	D	E	F	ØG	H	J	ØK	L	ØM	N	P	Sq	Q	S (NPT)
* VT45	-	1.97	1.42	-	1/4"-20 X 0.35	10-24 UNC x 0.32 5.94	2.46	2.60	0.79	0.87	0.47	0.55	1.18	3.15	-	-	-	0.43	0.47	1/8	
VT55	2.76	1.97	1.42	5/16"-18 x 0.47	1/4"-20 X 0.35	10-24 UNC x 0.32 6.61	2.87	2.97	0.79	0.59	0.47	0.55	0.92	3.15	0.55	0.39	1.28	0.43	0.47	1/8	
VT65	2.76	1.97	-	5/16"-18 x 0.47	1/4"-20 X 0.35	-	8.37	3.33	3.46	0.79	0.70	0.55	0.55	1.18	3.15	0.55	0.39	1.28	0.55	0.63	1/4
VT75	2.76	1.97	-	5/16"-18 x 0.47	1/4"-20 X 0.35	-	9.25	3.68	3.86	0.79	0.70	0.55	0.55	1.18	3.15	0.75	0.51	1.28	0.67	0.75	1/4
VT85	2.76	1.97	-	5/16"-18 x 0.47	1/4"-20 X 0.35	-	10.80	4.15	4.28	0.79	0.83	0.67	0.55	1.34	3.15	0.75	0.51	1.28	0.67	0.75	1/4
VT100	4.01	2.76	-	3/8"-16 x 0.59	5/16"-18 x 0.47	-	11.58	4.80	4.95	0.79	0.91	0.67	0.55	1.50	3.15	0.87	0.63	1.28	0.87	0.94	1/4
VT115	4.92	4.01	2.76	1/2"-13 x 0.71	3/8"-16 x 0.59	5/16"-18 x 0.47	13.80	5.49	5.53	1.18	1.18	0.79	0.79	1.85	5.12	0.87	0.63	1.28	0.87	0.94	1/4
VT125	4.92	4.01	-	1/2"-13 x 0.71	3/8"-16 x 0.59	-	15.95	5.87	6.00	1.18	1.18	0.79	0.79	1.85	5.12	1.18	0.87	2.13	0.87	0.94	1/4
VT150	4.92	4.01	-	1/2"-13 x 0.71	3/8"-16 x 0.59	-	18.80	7.18	7.34	1.18	1.50	1.18	0.79	2.16	5.12	1.18	0.87	2.13	1.06	1.14	1/4
VT175	4.92	4.01	-	1/2"-13 x 0.71	3/8"-16 x 0.59	-	20.83	8.27	8.46	1.18	1.69	1.26	0.71	2.44	5.12	1.18	0.87	2.13	1.06	1.14	1/4
VT200	6.50	4.92	-	3/4"-10 x 1.18	1/2"-13 x 0.71	-	25.27	9.19	9.76	1.18	1.97	1.42	0.71	2.83	5.12	1.38	-	2.52	1.42	1.50	1/4

\* 045 size actuator pinion design permits pinion to be inserted from top or bottom of the actuator to use all three bolt circles for mounting. Top mounting dimensions PCD - 1.65", Tapping 10-24 UNC x 0.32" DEEP. Bottom mounting dimensions (refer to chart).

# Torques (Lb-Inch)

Actuator Weights (Lb)											
Size	VT45	VT55	VT65	VT75	VT85	VT100	VT115	VT125	VT150	VT175	VT200
Double Acting	1.8	3.1	4.8	6.2	8.8	12.8	19.2	24.5	42.3	62.8	99.2
Spring Return	2.2	3.5	5.7	7.3	10.8	15.2	22.9	30.0	51.4	75.8	122.3

Double Acting Actuator Torque Data (Lb-Inch)							
Size	Air Supply Pressure (Psi)						
	40	60	80	90	100	120	
VT45	80	97	142	150	177	203	
VT55	133	177	248	274	319	363	
VT65	221	292	407	443	522	593	
VT75	336	451	620	673	788	903	
VT85	487	655	894	974	1142	1301	
VT100	752	1000	1381	1505	1752	2000	
VT115	1239	1655	2274	2478	2894	3310	
VT125	1611	2151	2956	3221	3761	4301	
VT150	2788	3717	5106	5576	6505	7434	
VT175	4142	5514	7584	8275	9655	11036	
VT200	6310	8408	11558	12611	14718	16815	

Actuator Volumes (Inc)											
Size	VT45	VT55	VT65	VT75	VT85	VT100	VT115	VT125	VT150	VT175	VT200
Opening	4.6	9.2	15.9	23.2	34.2	51.3	88.8	113.8	196.2	289.3	433.3
Closing	4.7	12.2	24.4	34.2	52.5	74.4	119.3	162.3	272.5	406.9	646.1

Actuator Speeds (sec.) are at 80 Psi & Orifice dia. of approx 0.16 inch.											
Size	VT45	VT55	VT65	VT75	VT85	VT100	VT115	VT125	VT150	VT175	VT200
Open Stroke/ Close Stroke	0.2	0.3	0.35	0.45	0.6	0.8	1.0	1.3	1.5	2.0	3.5

Spring Return Actuator Torque Data (Lb-Inch)																
Size	Spring/ Piston	Air Supply Pressure (Psi)												Spring Stroke		
		40		60		80		90		100		120				
		PB	PE	PB	PE	PB	PE	PB	PE	PB	PE	PB	PE	SB	SE	
VT45	2	44	18	71	44	106	88	115	97	142	124	168	150	53	26	
	3					88	53	106	71	133	97	150	124	71	44	
VT55	3	88	53	133	97	203	168							71	44	
	4			115	71	186	142	203	168	248	212			97	62	
	5					168	115	186	142	239	186	283	230	124	71	
VT65	6					150	88	177	115	221	159	265	204	142	88	
	3	142	97	221	168	327	283							115	71	
	4			195	124	301	239	336	274	416	345			150	97	
VT75	5					274	195	310	230	389	310	460	381	186	115	
	6					248	150	292	195	363	266	434	336	230	142	
	3	195	115	310	230	478	398							195	133	
VT85	4			257	159	425	327	487	381	593	496			266	177	
	5					381	248	434	310	549	416	664	531	327	212	
	6					327	177	389	230	496	345	611	460	398	257	
VT100	3	292	186	451	345	699	593							274	177	
	4			389	239	637	487	717	566	876	735			363	239	
	5					566	389	646	469	814	628	974	788	460	292	
VT115	6					504	283	584	363	743	531	912	690	549	354	
	3	451	274	699	522	1080	903							434	266	
	4			602	363	982	743	1106	867	1354	1115			575	354	
VT125	5					885	584	1009	708	1257	956	1505	1204	717	443	
	6					779	425	903	549	1159	797	1407	1044	858	531	
	3	761	487	1177	894	1797	1522							681	434	
VT150	4			1018	646	1637	1266	1841	1469	2257	1885			912	575	
	5					1478	1018	1682	1221	2098	1637	2514	2044	1133	717	
	6					1319	761	1522	965	1938	1381	2354	1797	1363	858	
VT175	3	1000	646	1540	1186	2345	1991							867	549	
	4			1336	867	2142	1673	2407	1938	2947	2478			1159	735	
	5					1938	1354	2204	1620	2744	2160	3275	2691	1443	920	
VT200	6					1735	1027	2000	1301	2540	1832	3071	2372	1735	1106	
	3	1575	1000	2505	1929	3903	3319							1611	1089	
	4			2106	1336	3496	2726	3965	3195	4894	4116			2142	1451	
VT125	5					3096	2133	3558	2593	4487	3523	5417	4452	2682	1814	
	6					2691	1531	3160	2000	4089	2930	5018	3859	3222	2177	
	3	2443	1602	3823	2983	5894	5054							2283	1522	
VT150	4			3266	2142	5328	4213	6018	4903	7399	6275			3036	2027	
	5					4770	3363	5461	4054	6833	5434	8213	6815	3797	2540	
	6					4204	2522	4894	3213	6275	4594	7656	5965	4558	3045	
VT175	3	3717	2514	5824	4620	8975	7771							3416	2328	
	4			4956	3354	8116	6505	9160	7558	11267	9656			4549	3107	
	5					7249	5240	8302	6293	10400	8399	12506	10497	5691	3877	
VT200	6					6390	3974	7435	5027	9541	7134	11630	9231	6824	4655	

Actual torques are in the range of ±5% of the above values.

In between torque values to be interpolated.

SE= Spring End Torque, SB= Spring Break Torque, PE= Pneumatic End Torque, PB= Pneumatic Break Torque

# Features

## 1. Travel Stops

Two external travel stops permit adjustments of +/- 5 degree. Note : Travel stops are located on end caps on size 045 only.

## 2. Bearings

Top quality bearings and seals for low friction and high cycle life to ensure trouble free operation. Same bearings are used for both high and low temperature operations.

## 3. Spring Cartridges

Modular pre-loaded spring cartridges with metal spring guides for use in both high and low temperature applications.

## 4. Extruded Aluminum Body

Hard anodized extruded aluminum body with honed internal surface for strength, high cycle life, and low frictional resistance.

## 5. Shaft Insert

Unique output shaft insert can be selected from a variety of standard sizes, including double D, ISO square, and round and keyed, or can be custom designed to fit any output shaft configuration.

## 6. Blow-Out Proof Shaft

Guide bar in pistons provides an inherent blow-out proof shaft design.

## 7. Wide Base Design

Wide actuator base design option can be adapted to mount valve designs requiring wider than EN ISO 5211 drilling.

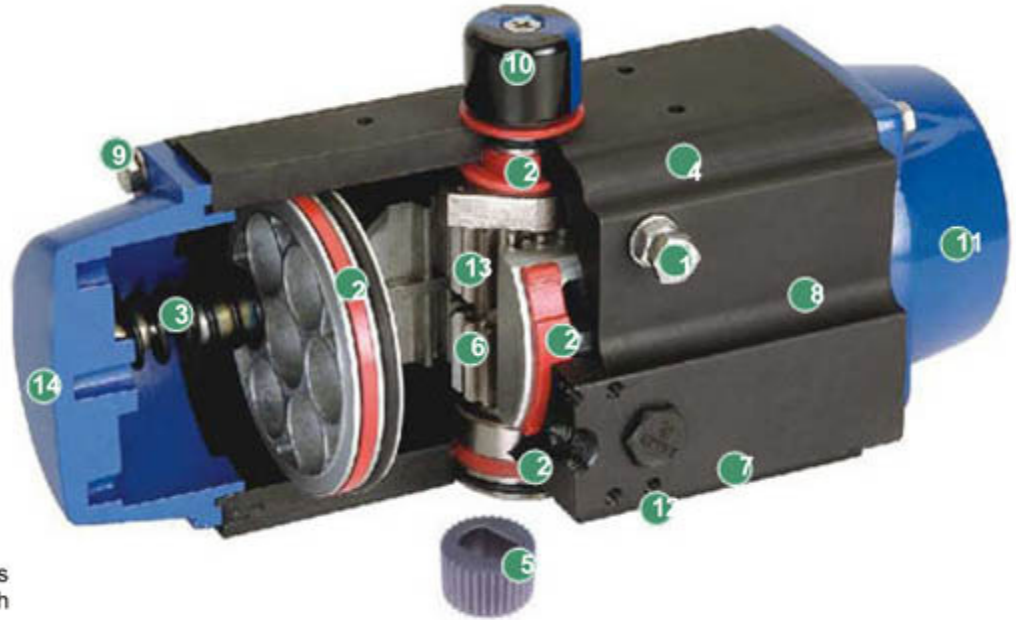

## 8. Dual Rack and Pinion Design

Dual rack and pinion design offers double acting and fail safe operations in same body. Reverse rotation can be accomplished by simply inverting the pistons.

## 9. Fasteners

Internal and external stainless steel fasteners and specially coated springs provide corrosion resistance in a variety of environments.

## 10. Position Indicator

Unique position indicator can be indexed to show alternate positions. Top of actuator has a NAMUR slot to engage with all popular sensors and positioners.

## 11. End Caps

Standard end caps are rounded with no crevices to accumulate contamination. Optional end caps are available to provide 100% stroke adjustment in one direction.

## 12. Actuator Mounting

Manufactured in full compliance with the latest requirements of EN ISO 5211, with provisions for mounting solenoid valves and accessories, comply with NAMUR VDI / VDE 3845.

## 13. Alloy Steel Shaft

High strength alloy steel shaft with electrolysis nickel plating protection for maximum wear and corrosion resistance.

## 14. Compact Modular Design

Compact modular design with same body and end caps for double acting and spring return designs combined with a shaft insert design to offer the most efficient use of inventory.

## 15. Size 045 Actuator

Size 045 actuator pinion design permits pinion to be inserted from top or bottom of the actuator to use all three bolt circles (F03, F04, F05) for mounting. The female drive of the pinion is available in the 9 mm and 11 mm square.

**VALTORC INTERNATIONAL**  
**P.O. BOX 1928**  
**KENNESAW, GA 30156**

**AJBENTAL@VALTORC.COM**  
**WWW.VALTORC.COM**  
**1-866-VALTROC**

